

## Radiata Cladding



### Overview

Imbue Radiata Cladding is created from thermally modified New Zealand plantation timber.

The thermal modification process means Imbue Radiata Cladding has enhanced stability, reduced resin content, is a beautiful homogeneous brown colour, with natural durability.

Imbue Radiata Cladding is available in a range of architectural profiles and can be supplied factory coated in Protector – a high performance pigmented exterior oil.

**Wood species:** Thermally Modified Radiata Pine (Pinus Radiata).

### Made to order profiles (mm):

#### WB12



90x19 (70mm cover)

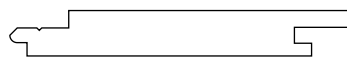

138x19 (118mm cover)

#### WB18

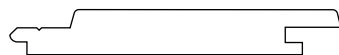

135x19 (115mm cover)

#### TG21



137x18 (127mm cover)

#### TG27

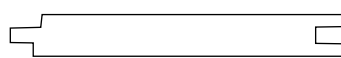

137x18 (127mm cover)

### Other profiles available on request.

Profiles can be supplied with smooth, bandsawn or brushed finish.

A textured finish is recommended for stain/oil coating.

**Lengths:** Solid lengths from 2.1–4.8m.\*

\*Product is supplied as standard in 'random length' or otherwise lengths at Imbue's option. Specified fixed lengths may be available but are subject to conditions including minimum quantity, price premium and availability. Please check with Imbue prior to placement of order.



# Radiata Cladding

**Colours:** Colours presented are in Protector coating and are indicative only. Colour may change/fade as a part of the natural weathering process. Coating on Smooth dressed timber will not last as long as bandsawn, brushed or textured timber.



Nero

Ebony

Graphite

Walnut

Teak

Clear

Natural

Straw

Patina

White

Some colours may not be stocked by the local distributor, please enquire for availability and lead time prior to specification. Refer to the Technical Data Sheet – Protector for more information.

## Finishes:



Fine bandsawn

Brushed

Sanded smooth

## Product Specifications

**Name:** Imbue Radiata Cladding.

**Quality: Select Grade/**Front face and edges virtually free of any defects but with one edge knot and one small face defect allowed per piece in 20% of boards only. Back side with some defects allowed according to Dressing Grade (equal to CE EN14915 Grade A for use as claddings and BS1186:3 1990 Grade CSH and BS EN942 Grade J5 for use in joinery). See Appearance Grade Rules.

**Finish:** Fine bandsawn face as standard (some variation in the visual appearance of the bandsawn finish can be expected). Smooth sanded or other textured finish may be available on request.

**Durability:** Durability Class 1 (EN350) and Class 2 (AS5604) – above ground.

**Preservative treatment:** Available optionally treated with LOSP azole-based preservation system according to H3 (AS1604) and Use Class 3 (EN335).

Treatment is required for termite zones.

**Warranty:** 15 years against fungal decay (subject to terms and conditions).

**Moisture content:** Approx. 7% MC (+/-2%) at time of dispatch. Moisture content may vary depending on environment.

### Expected dimensional change in structure:

Width expansion      approx 3–4%

Thickness expansion      approx 2%

Length expansion      approx 0.25%

(From 7%MC to fibre saturation – variation will occur between boards.)



# Radiata Cladding

---

**Average density:** ~420 kg/m<sup>3</sup>.

---

**Fire:** EN13501-1 D-s1-d0 (Tested uncoated with A1/A2 substrate), ASTM E84-Class B, AS3837-Group 3.

---

**Hardness:** Low (2.5kN Janka).

---

**Thermal properties:** ~0.095 W/(mK) (EN12667).

---

**pH (indicative):** 3.9.

---

**Curved walls (min radius):** WB18 135x19mm – 2300mm, WB12 90x19mm – 800mm.

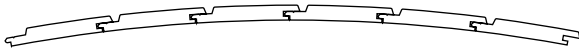

**Compatibility:** Can be placed in contact with most materials including aluminium, galvanised and stainless steel however increased acidity of the timber may require separation from zinc. Use stainless steel fixings for exterior applications. Cross linking PVA, PU, MUF glues and RF resins can be used. Unique properties of the timber including dryness may affect glue bond performance, always check with adhesive manufacturer and conduct testing prior to use.

---

**Coating:** Imbue Radiata will take most stains, penetrating oils and paints well, though up-take of coating is generally higher than normal. At least one coat must be applied all sides including back face, edges and ends before fixing. At least two coats must be applied to the front face and edges. Penetrating erosion stains are recommended. Smooth dressed timber must be sanded with 120 grit sandpaper prior to coating.

Available factory pre-coated with 1 or 2 coats.

---

**Certification:** Forest Stewardship Council® (FSC®) Certified FSC MIX, FSC-C010962, SGS-COC-004944.

## Product Handling

- Cladding and accessories must be kept clean, dry well ventilated and out of the weather prior to installation.
- Timber must be stored horizontally on bearers at least 100mm (4") off the ground in a well ventilated area.
- Extra care must be taken during installation so as not to damage the factory finish of the boards.
- Wear dust mask, eye protection when cutting timber.

## Installation Overview

### Substrate:

- Timber framing must be to local standards and comply with building regulations.
- Fix cladding over a waterproof, breathable membrane, or other suitable waterproof substrate such as masonry or concrete. A membrane is not required for concrete or masonry substrate. A non combustible substrate may be required depending on local fire regulations please check prior to specification and installation.
- Waterproof membranes must have minimum permeability of 0.5 g/m<sup>2</sup> h.mm Hg with minimum overlaps in accordance with manufacturers instructions and local building code requirements. A UV resistant membrane shall be used for open joint louvre type installation.

### Cavity battens:

- Use Class (H3) or equivalent pressure treated kiln dried structurally graded timber cavity battens fixed with minimum hot dipped galvanised flat head nails or 10g screws or masonry anchors (for concrete walls) staggered along the batten at maximum 600mm (24" OC) centres and with minimum 40mm (1.57") fixing penetration into substrate.



# Radiata Cladding

- For horizontal cladding use minimum 18mm (11/16") thickness cavity battens with width sized to match studs.
- For vertical cladding, structurally fix minimum 38x45 (2x2") or 35x70mm (2x3") or 32x90mm (5/4"x4") cavity battens horizontally over the top of minimum 18mm thick pressure treated timber counter-battens or 10mm (3/8") thickness shims at maximum 600mm (24" OC) centres to match fixing points This allows free movement of moisture and airflow up the back of the cavity.

## Fixing:

- Fix boards either vertically or horizontally as appropriate to the profile type specified with cavity batten spacings at maximum 600mm centres (24" OC).
- For best results we recommend that only stainless steel fixings are used. However, for secret fix profiles where fixing heads are covered, hot dipped galvanised fixings may be used. Stainless steel fixings must be used in areas near the sea.
- Fix profiles with self-drilling self-countersinking head screws so as to achieve minimum 30mm (1-1/4") penetration into the stud or structural cavity batten. Drive fixings so they are flush with the timber surface. Screw fixing is recommended.
- Profiles <140mm (5-1/2") wide may be hidden or face fixed with a single screw. Profiles >140mm (5-1/2") wide must be face fixed with two screws.
- Fixings at ends of boards must be at least 12mm (1/2") from end, and must be pre-drilled before applying fastener. Ensure minimum 2mm (1/16") expansion gap to back of boards.

## Fixing Overview

### End grains:

- All exposed end grains and notches must be sealed using Protector – End Seal or equivalent water repellent end grain preservative.

### Joins:

- Joins between cladding board ends must be made over battens only, using a 35 degree mitre, and application of sealant at the join e.g. Sikaflex 11FC.

### Windows and doors:

- Window and door openings must be detailed and flashed appropriately to divert water away from the interior walls and allow adequate space for drainage and drying in service.

### Corners:

- External and internal corners shall be made over back-flashings using appropriate mouldings in accordance with Imbue details. Mitred corners are not recommended.

### Base of wall:

- Cladding must finish minimum 100mm (4") above paved surface or 175mm (7") above un-paved surfaces. Base of cladding must not sit directly into flashings or other cladding materials such as masonry. Minimum 5mm (1/4") gap must be left to flashings allowing fall to shed water away from the wall cavity.
- For vertical cladding, at base of wall cut ends at a 15 degree angle to provide a drip line.
- Use perforated cavity base closer flashing with minimum 50 cm<sup>2</sup> (7 3/4 sq inches) of air inlet per metre to allow drainage, air flow and keep out vermin.
- Use Imbue mouldings finish to seal top of wall and for corners.

### Finishing:

- We recommend at least one coat of Protector or proprietary specified wood stain to be applied to all sides prior to installation and then a further one or two coats applied once boards are fixed in place according to manufacturer's instructions. Smooth dressed timber must be prepared with 120grit sand paper prior to coating. Thoroughly seal all exposed ends.



# Radiata Cladding

Fixing details:

## Horizontal T&G 'Nickel Gap' Siding – Hidden Fixed

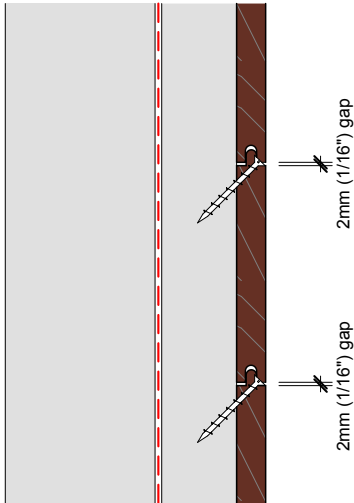

Profiles <140mm (5-1/2") width only.

## Horizontal T&G Siding – Hidden Fixed

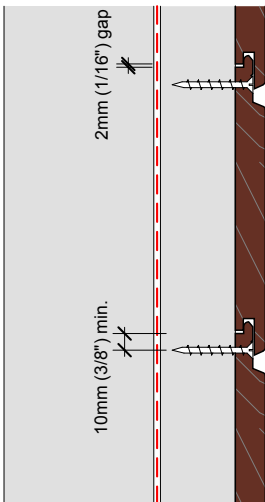

## Vertical T&G Siding – Hidden Fixed

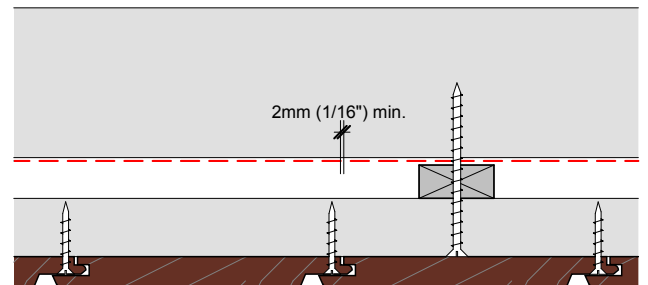

Profiles <140mm (5-1/2") width only may be hidden fixed.

## T&G Siding – Face Fixed

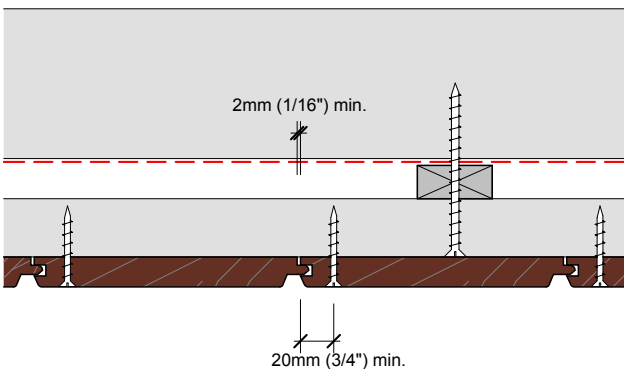

Profiles <140mm (5-1/2") width may be fixed with a single screw.

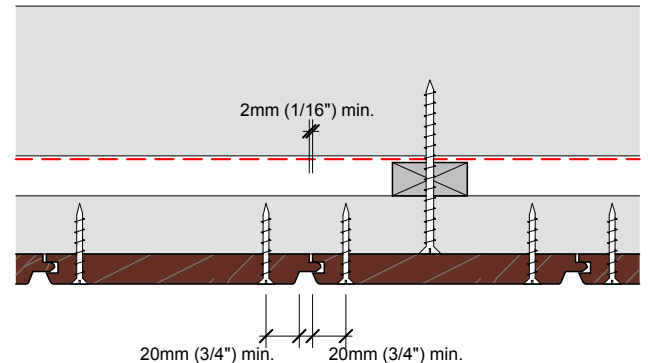

Profiles >140mm (5-1/2") wide must be face fixed with two screws.



# Radiata Cladding

## Maintenance

- Wash down every 12 months with gentle pH neutral detergent, warm water and soft brush. Do not use jet pressure wash downs with Imbue Cladding.
- If possible it is recommended to apply a further coat of oil after approx 12 months of weathering. When timber is dry.
- Re-coat every 3–4 years or as required to maintain colour and integrity of coating when timber is dry. Re-coat period may be longer or shorter depending on climatic conditions and/or positioning of cladding to the sun. Preparation with an oxalic timber cleaner is recommended prior to coating. Follow recommendations given on the Protector Technical Data Sheet.
- For other specialty finishes please refer to specific manufacturer’s literature.

## Lightening of the Timber:



**Teak**  
As delivered

**Teak**  
Weathered exterior install

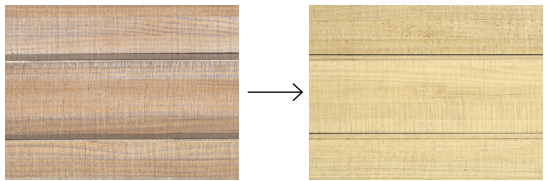

**Straw**  
As delivered

**Straw**  
Weathered exterior install

We cannot guarantee against wear or color changes to any products which result from weather, sun, wind and/or the natural aging process of the wood.

## Surface checking:

- Checking (cracks) may be observed on the face and ends of Imbue Radiata timber. Checks are acceptable to install. Checking may become more apparent as the material weathers naturally in place. Some cupping may also occur as the timber acclimatizes to climatic conditions. These are not defects and are considered a natural part of this wood product. Maintenance with a coating and thorough sealing of end grains with sealer will improve long term weathering characteristics.

## Uncoated cladding weathered 18 months:

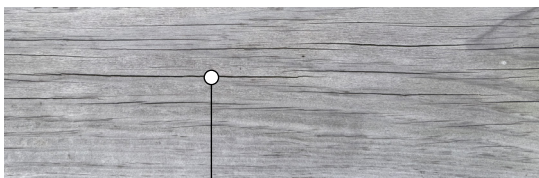

Surface checking